



US011523693B2

(12) **United States Patent**  
**Spiro et al.**

(10) **Patent No.:** **US 11,523,693 B2**

(45) **Date of Patent:** **Dec. 13, 2022**

(54) **SNAP-FIT FRAMING SYSTEM**

(56) **References Cited**

(71) Applicant: **Tracer Imaging LLC**, Ossining, NY (US)

U.S. PATENT DOCUMENTS

(72) Inventors: **Steven M. Spiro**, Chappaqua, NY (US);  
**Ryan Kelly**, Scarsdale, NY (US)

|             |        |                 |
|-------------|--------|-----------------|
| 1,463,150 A | 7/1923 | Carisen         |
| 2,155,729 A | 4/1939 | Mainieri        |
| 2,470,416 A | 5/1949 | Silver          |
| 2,523,383 A | 9/1950 | Majkrak         |
| 2,567,743 A | 9/1951 | Stafford et al. |

(Continued)

(73) Assignee: **TRACER IMAGING LLC**, Ossining, NY (US)

FOREIGN PATENT DOCUMENTS

(\*) Notice: Subject to any disclaimer, the term of this patent is extended or adjusted under 35 U.S.C. 154(b) by 0 days.

|    |            |         |
|----|------------|---------|
| DE | 199 00 831 | 5/2000  |
| EP | 1149550    | 10/2001 |

(Continued)

(21) Appl. No.: **17/388,762**

OTHER PUBLICATIONS

(22) Filed: **Jul. 29, 2021**

"5x7 Double Picture Frame for Tabletop, Slide in Rear Backer—Silver" (DISPLAYSZGO) Nov. 17, 2015 (17.11.2015); retrieved from internet 06.04.2018; <<https://web.archive.org/web/20151117081709/https://www.displays2go.com/p.12957/Metal-Picture-Frame-Displays-Two-5-x-7-Prints>>; entire document.

(Continued)

(65) **Prior Publication Data**

US 2022/0031095 A1 Feb. 3, 2022

**Related U.S. Application Data**

(60) Provisional application No. 63/059,249, filed on Jul. 31, 2020.

*Primary Examiner* — Gary C Hoge

(74) *Attorney, Agent, or Firm* — Leason Ellis LLP

(51) **Int. Cl.**

*A47G 1/10* (2006.01)  
*A47G 1/06* (2006.01)

(57) **ABSTRACT**

A frame system according to one embodiment includes a hollow outer frame element that includes a plurality of recesses formed along inner faces of walls of the outer frame element. The outer frame element further includes a plurality of ribs formed along the inner face and an inner landing that protrudes inwardly into a center opening of the outer frame element. The frame system also includes a back plate configured for insertion into the center opening. The back plate includes a plurality of locking ribs for reception within the plurality of recesses to generate a snap-fit attachment of the back plate to the hollow outer frame element.

(52) **U.S. Cl.**

CPC ..... *A47G 1/10* (2013.01); *A47G 2001/0677* (2013.01)

**18 Claims, 12 Drawing Sheets**

(58) **Field of Classification Search**

CPC ..... *A47G 1/10*; *A47G 2001/0677*; *A47G 1/0605*; *A47G 2001/0694*

See application file for complete search history.

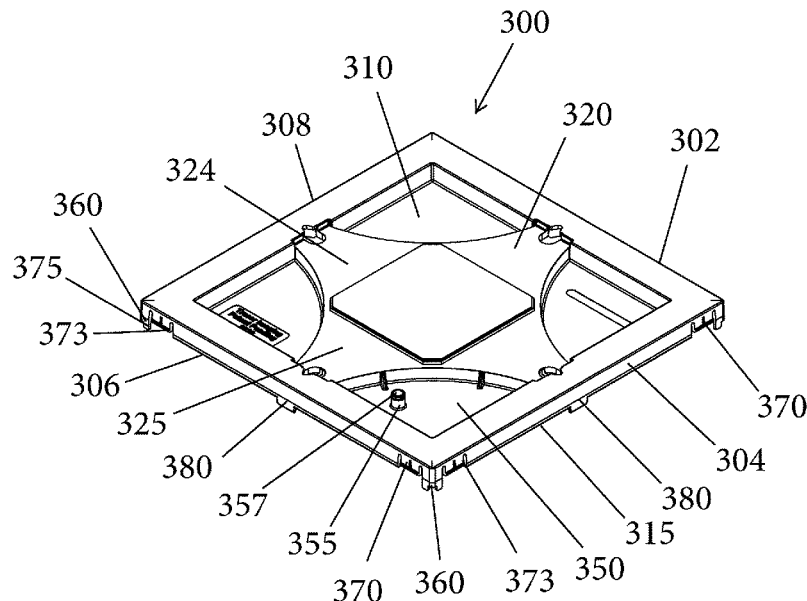

(56)

References Cited

U.S. PATENT DOCUMENTS

2,806,309 A \* 9/1957 Goldberg ..... G03B 21/64  
40/781

2,959,882 A 11/1960 Krull

3,127,695 A 4/1964 Driscoll

3,294,429 A 12/1966 Halp

3,429,602 A 2/1969 Dirilgen

3,529,653 A 9/1970 Fey, Jr.

3,579,886 A \* 5/1971 Hughes ..... G09F 1/12  
40/781

3,657,796 A 4/1972 Gohnauer

4,018,260 A 4/1977 Baslow

4,041,861 A 8/1977 Alter

4,144,660 A 3/1979 Lamb

4,197,686 A 4/1980 Baslow

4,201,359 A 5/1980 Baslow

4,286,400 A 9/1981 MacPherson

4,348,826 A 9/1982 Reim

4,432,152 A \* 2/1984 Daenen ..... A47G 1/065  
40/781

4,451,997 A 6/1984 Jones

4,485,574 A 12/1984 Bennetot

4,637,147 A 1/1987 Wolsey

4,762,076 A 8/1988 Wakaizumi

5,012,601 A \* 5/1991 Garland ..... G09F 1/12  
40/781

5,058,353 A 10/1991 Gartner

5,075,991 A 12/1991 Wenkman et al.

5,275,224 A 1/1994 Morris

5,307,575 A 5/1994 Ivansson et al.

5,466,086 A 11/1995 Goto

5,502,906 A 4/1996 Yamawaki

5,579,595 A 12/1996 Dutton

6,138,741 A 10/2000 Stobart

6,189,252 B1 2/2001 Dowzall

6,253,471 B1 7/2001 Strauh

6,347,466 B1 2/2002 Lackner

6,354,031 B1 \* 3/2002 Meur ..... G09F 1/12  
40/781

6,722,096 B2 4/2004 Von Arx

6,729,057 B1 5/2004 Lu

D491,374 S \* 6/2004 Bradford ..... G09F 1/12  
D6/310

7,293,378 B2 11/2007 Bihr

7,735,541 B2 6/2010 Ocampo

8,793,910 B2 8/2014 Froio

8,936,065 B1 1/2015 Gillespie

9,402,488 B2 8/2016 Morrish

10,532,606 B1 \* 1/2020 Gray ..... B44C 5/02

10,624,473 B1 \* 4/2020 Tsai ..... A47G 1/06

10,628,112 B2 4/2020 Hofmeister

2001/0014250 A1 8/2001 Plummer et al.

2003/0200712 A1 10/2003 Brownsell et al.

2004/0226208 A1 11/2004 Kownacki et al.

2005/0129460 A1 6/2005 Medcalf et al.

2007/0245650 A1 10/2007 Brown

2009/0031593 A1 2/2009 Kasuya

2010/0147471 A1 6/2010 Bull

2012/0090211 A1 4/2012 Price

2013/0067785 A1 3/2013 Davis

2013/0180142 A1 7/2013 Kressin

2013/0333851 A1 12/2013 Chen

2014/0352184 A1 12/2014 Hall

2015/0297001 A1 10/2015 Welch

2016/0296033 A1 10/2016 Feltrin

2017/0035221 A1 \* 2/2017 Huff ..... A47G 1/06

2017/0151772 A1 6/2017 Spiro et al.

2018/0199736 A1 7/2018 Spiro et al.

2019/0350387 A1 \* 11/2019 Bastian ..... A47G 1/1626

2020/0060444 A1 \* 2/2020 Katz ..... A47G 1/0627

2020/0397159 A1 \* 12/2020 Haney ..... A47G 1/06

2020/0397160 A1 12/2020 Spiro et al.

FOREIGN PATENT DOCUMENTS

FR 2 609 615 7/1988

GB 1 334 851 10/1973

JP 40-6073 2/1965

JP 49-19648 2/1974

JP 50-19535 3/1975

JP S62-271800 11/1987

JP S63 197585 12/1988

JP 09-263100 10/1997

JP 2003306000 10/2003

JP 2006001282 1/2006

JP 2008-194194 8/2008

JP 2009153680 7/2009

WO WO 2007/123394 11/2007

WO WO 2012/076370 6/2012

OTHER PUBLICATIONS

Non-Final Office Action in U.S. Appl. No. 16/902,733, dated Feb. 14, 2022 (39 pages).

\* cited by examiner

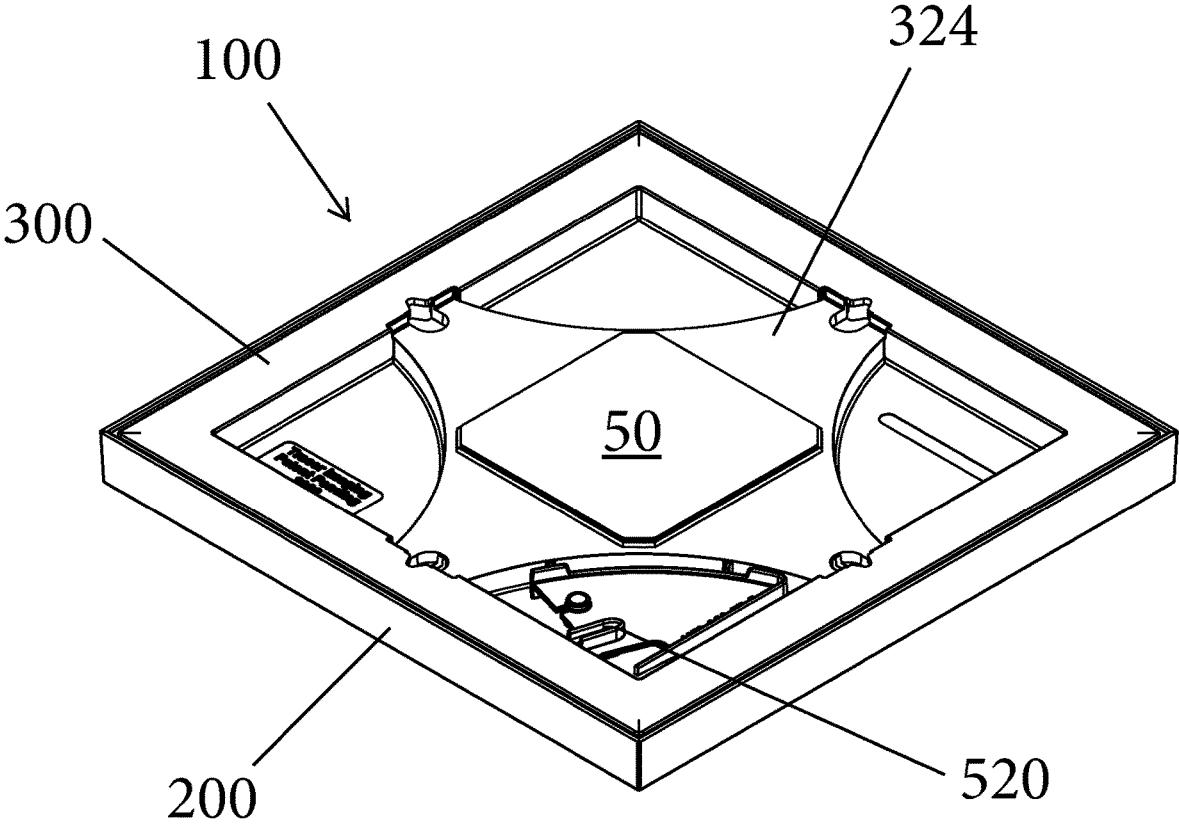

Fig. 1

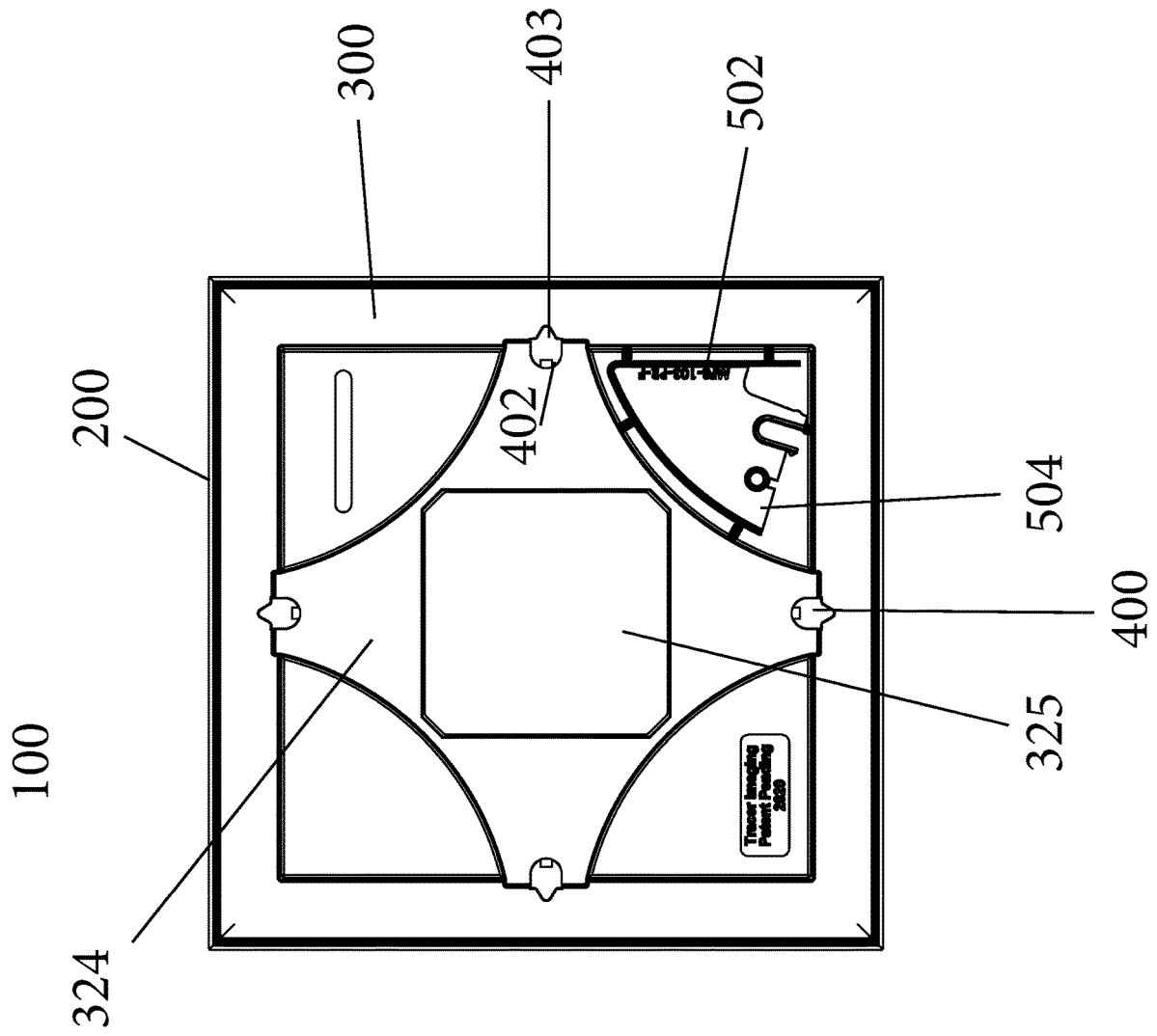

Fig. 2

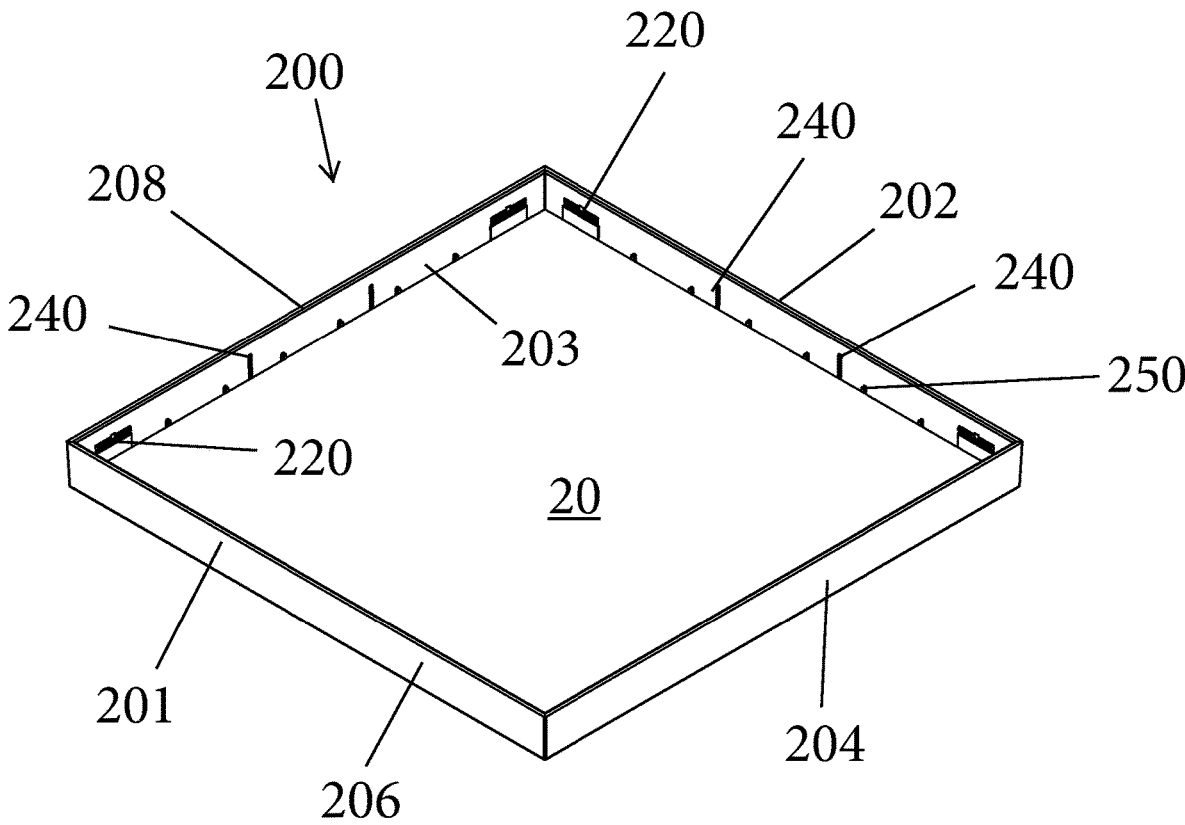
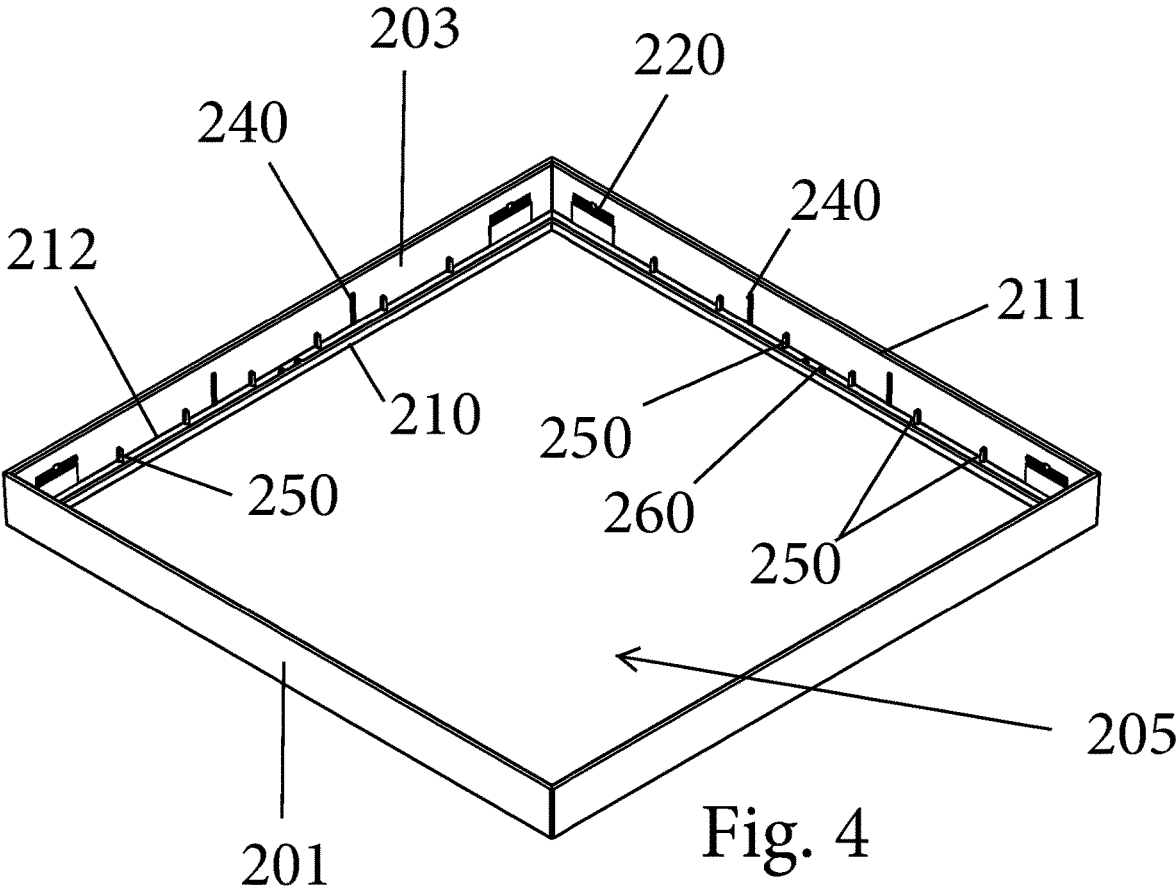

Fig. 3



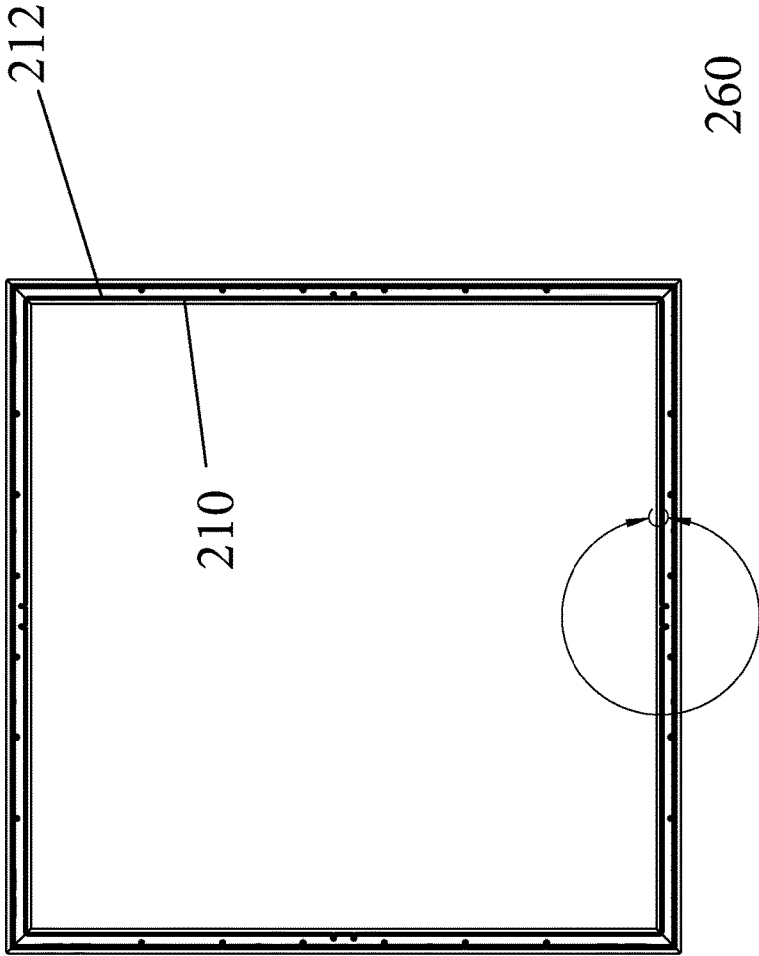

Fig. 5

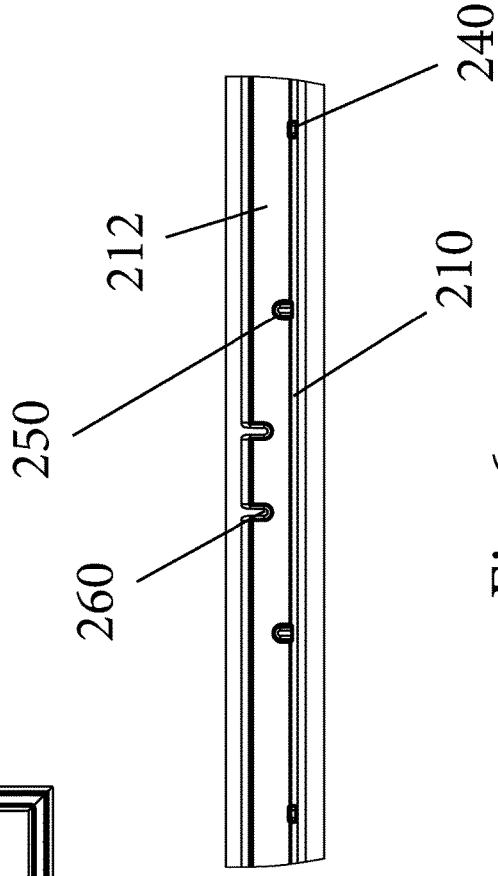

Fig. 6

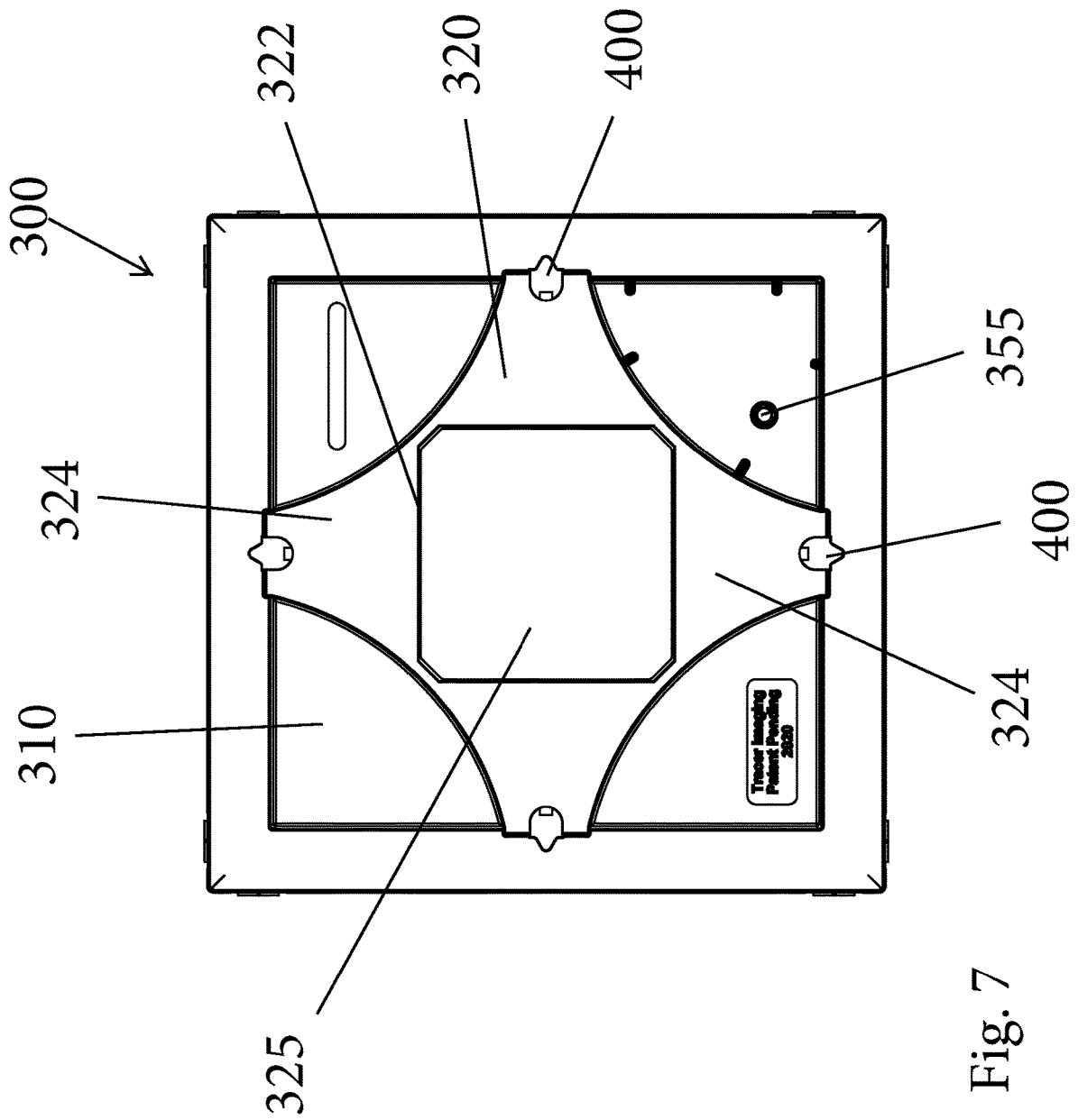

Fig. 7



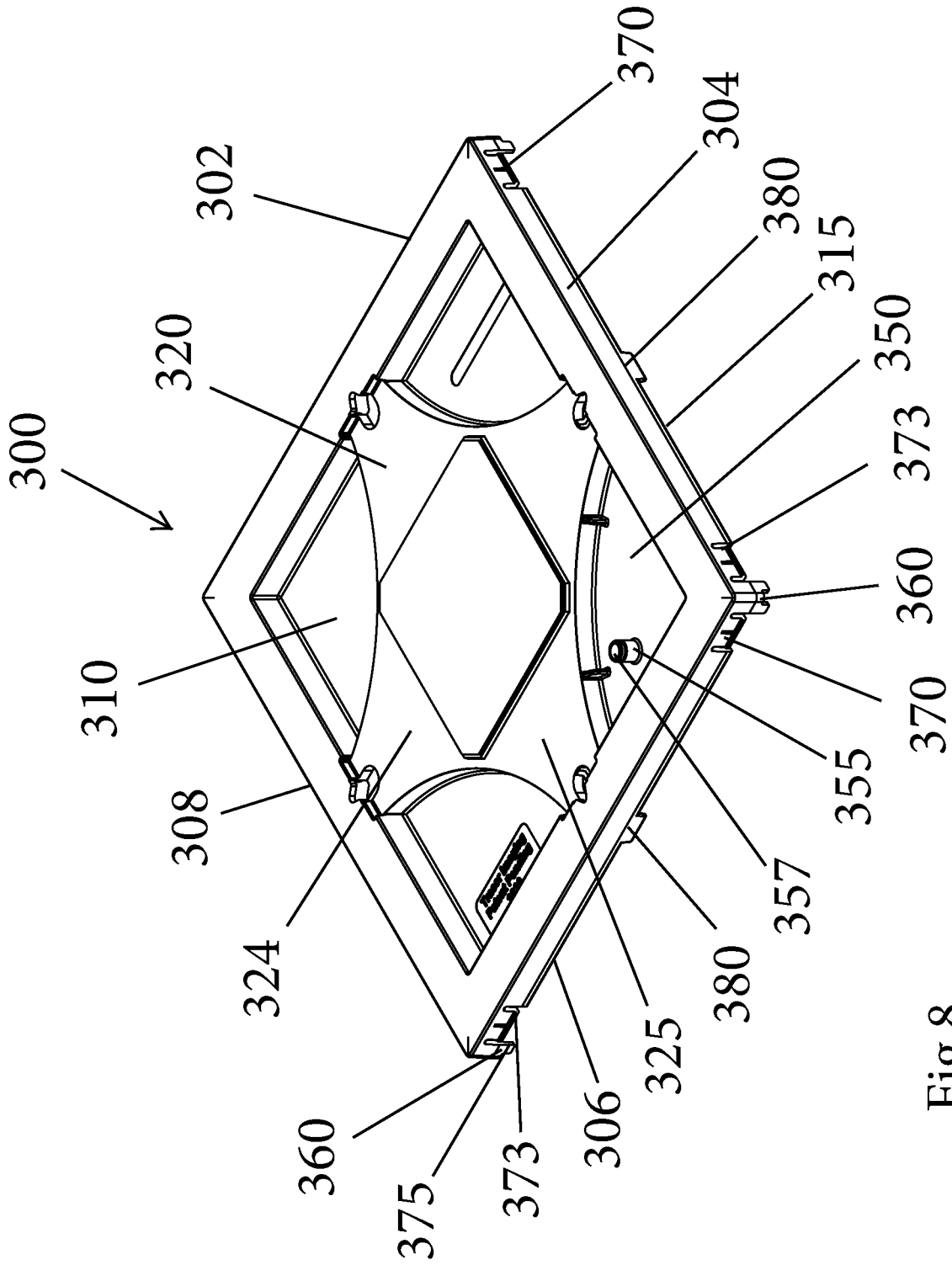

Fig 8

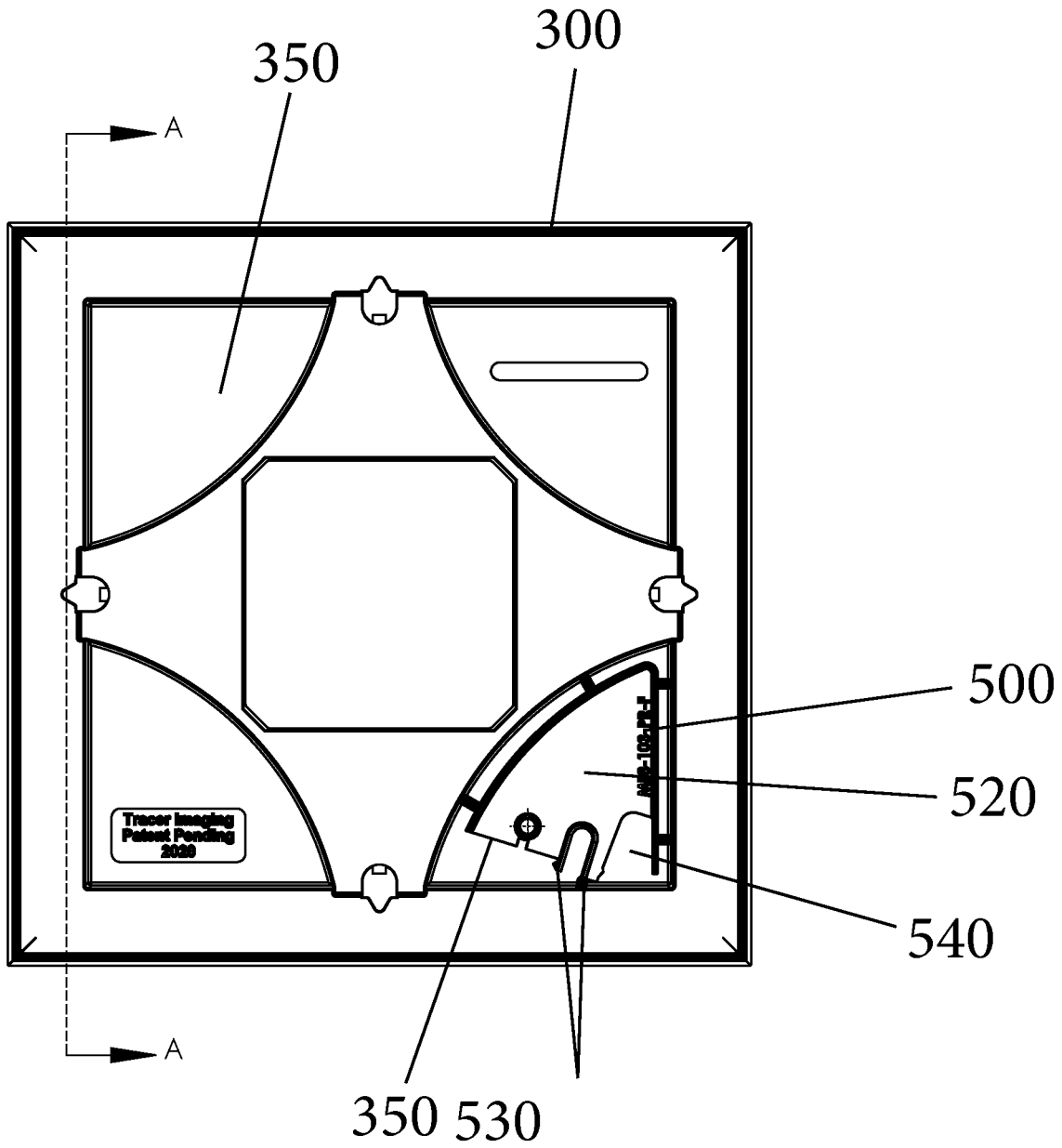

Fig. 9

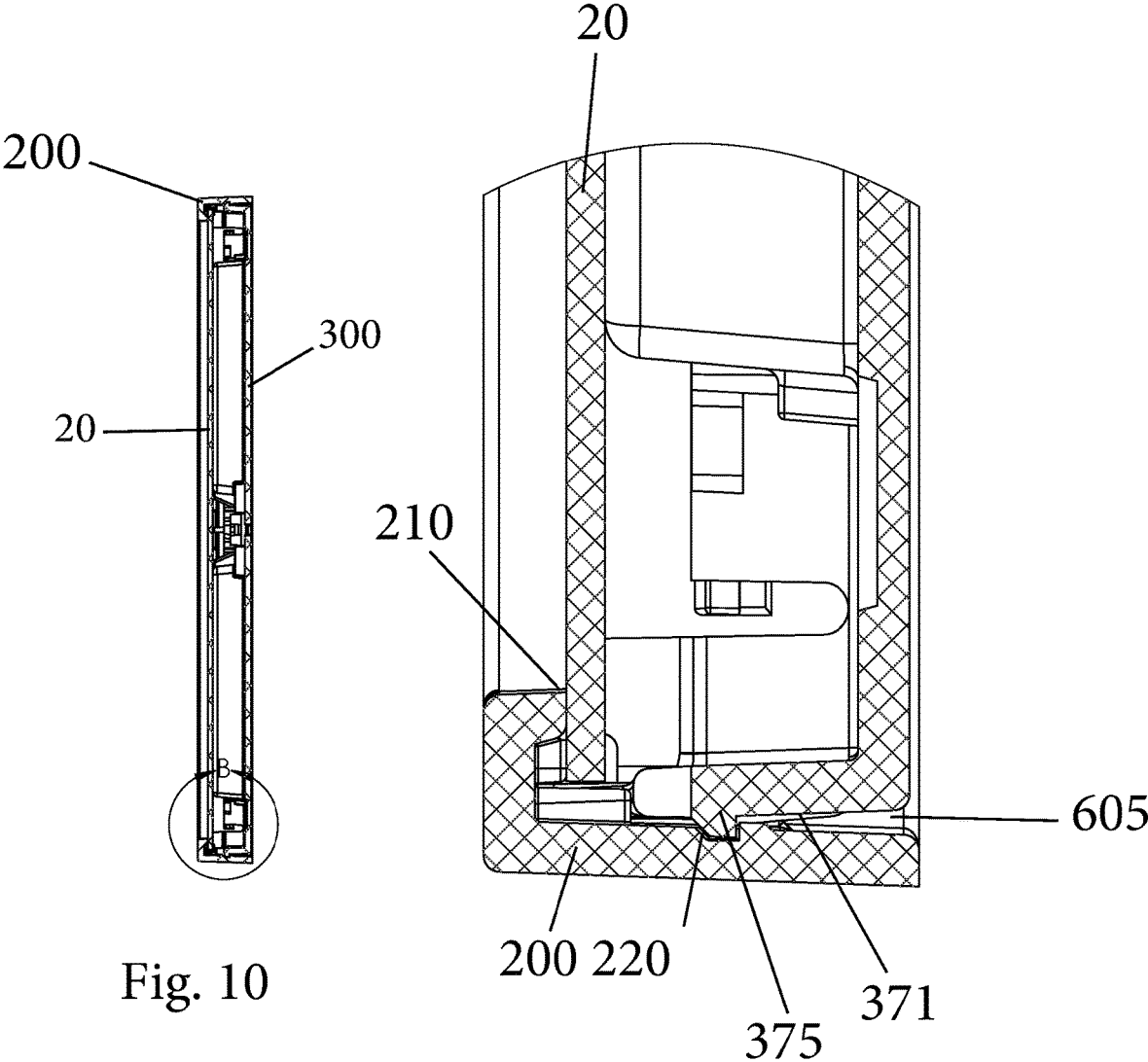

Fig. 10

Fig. 11

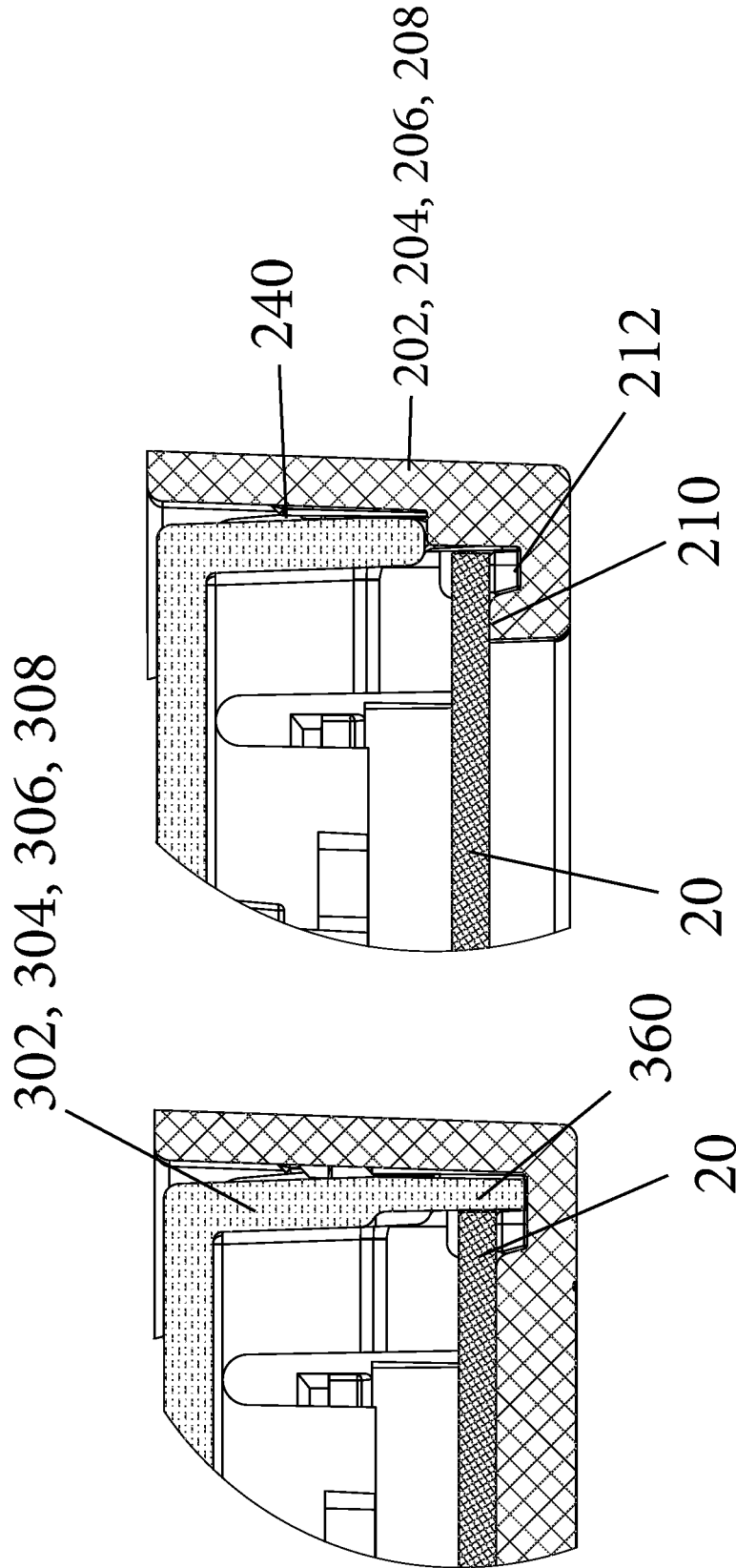

Fig. 12

Fig. 13

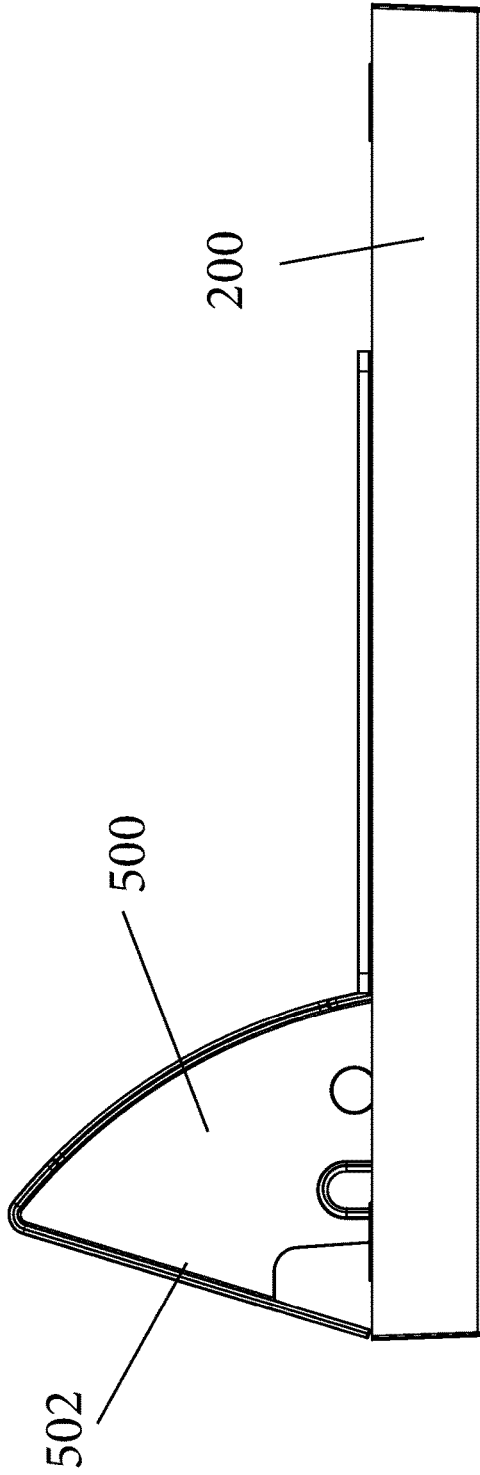

Fig. 14

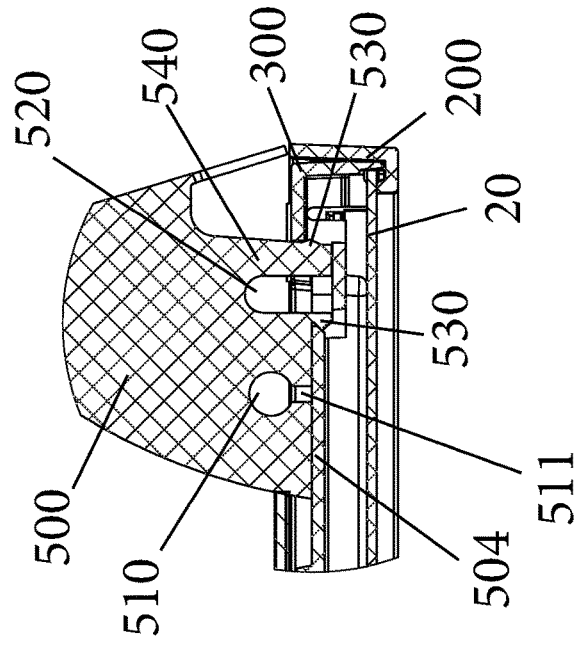

Fig. 15

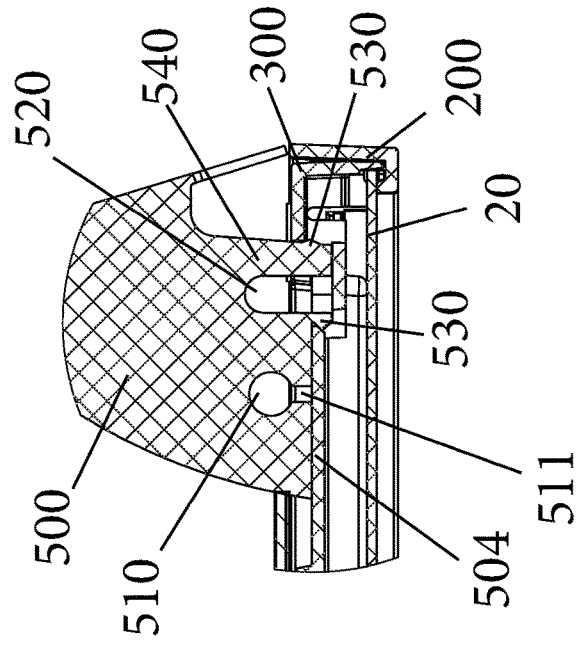

Fig. 16

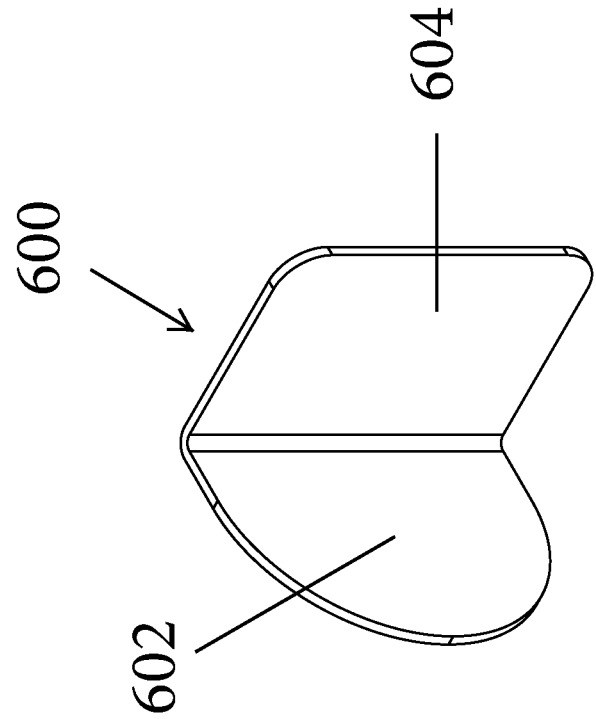

Fig. 18

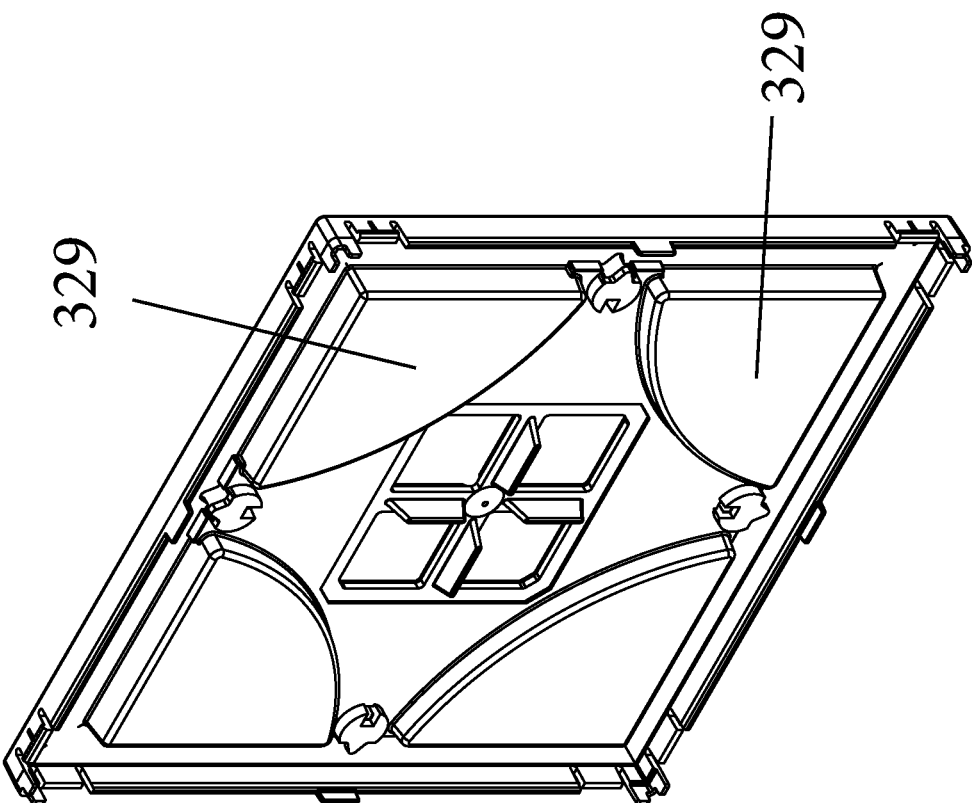

Fig. 17

1

**SNAP-FIT FRAMING SYSTEM****CROSS-REFERENCE TO RELATED PATENT APPLICATIONS**

This application is based on and claims priority to U.S. Provisional Patent Application 63/059,249, filed Jul. 31, 2020, the entire contents of which is incorporated by reference herein as if expressly set forth in its respective entirety herein.

**TECHNICAL FIELD**

The present disclosure is directed to a frame for displaying an object, such as a photograph or artwork, and more particularly, relates to a snap-fit framing (frame) system or assembly.

**BACKGROUND**

Frames have been used for many years to hold and display an object, such as artwork, a photo, etc. Traditionally, frames were formed of wood pieces that are attached to together at the corners of the frame. This type of construction and assembly was time consuming and costly. There is therefore a need for an alternative frame that is easy to assembly and provides additional features that improve the quality of the framed article and the framing experience.

**SUMMARY**

A frame system according to one embodiment includes a hollow outer frame element that includes a plurality of recesses formed along inner faces of walls of the outer frame element. The outer frame element further includes a plurality of ribs formed along the inner face and an inner landing that protrudes inwardly into a center opening of the outer frame element. The frame system also includes a back plate configured for insertion into the center opening. The back plate includes a plurality of locking ribs for reception within the plurality of recesses to generate a snap-fit attachment of the back plate to the hollow outer frame element.

**BRIEF DESCRIPTION OF THE DRAWING FIGURES**

FIG. 1 is a rear and side perspective view of a framed article in accordance with one embodiment;

FIG. 2 is a rear view of the framed article;

FIG. 3 is a rear perspective view of a first part (outer frame element) of the framed article with an image substrate being disposed within the outer frame element;

FIG. 4 is a rear perspective of the outer frame element without the image substrate;

FIG. 5 is a rear elevation view of the outer frame element without the image substrate;

FIG. 6 is an enlarged view of a wall segment of the outer frame element taken along the circle in FIG. 5;

FIG. 7 is a rear elevation view of a second part (back plate) of the framed article without the kickstand;

FIG. 8 is a rear perspective view of the back plate;

FIG. 9 is a rear elevation view of the back plate showing the kickstand secured thereto;

FIG. 10 is a cross-sectional view taken along the line A-A of FIG. 9;

FIG. 11 is an enlarged view of an end portion taken along the circle of FIG. 10;

2

FIG. 12 is another enlarged view of another cross-section of the back plate;

FIG. 13 is yet another enlarged view of another cross-section of the back plate;

FIG. 14 is a side elevation view of the assembled frame article with a kickstand in an attached position;

FIG. 15 is a cross-sectional view thereof;

FIG. 16 is an enlarged view of the kickstand taken along the circle of FIG. 15;

FIG. 17 is a front perspective view of the back plate; and

FIG. 18 is a perspective view of a disengagement tool.

**DETAILED DESCRIPTION OF CERTAIN EMBODIMENTS**

In accordance with the present disclosure, as illustrated in FIGS. 1-17, a framing system or assembly (kit) **100** is shown and described and is configured to create a framed article that can be displayed either on a wall or can stand upright on a flat surface, such as a table or desk. The framed article is configured to display an image that is part of an image substrate **20** (FIG. 3) that is held and displayed within the framing system **100**. The image substrate **20** is typically a rigid substrate on which an image is displayed. While the image substrate **20** is illustrated in FIG. 11 as a single layer, it will be appreciated that the image substrate **20** can include more than one layer, such as a rigid backing layer and a photo layer or the like. The image displayed can take any number of different forms including a paper clipping, a photo, artwork including a painting, or other artistic expression.

As described herein, the framing system **100** provides an easy to use and easy to assemble kit that allows a user to assemble the frame and position and retain the image substrate **20** therein. The framing system **100** has other accessories to allow it to be displayed in different ways, such as hanging on a wall or displayed on a flat table surface, etc.

The framing system **100** has two main parts, namely, an outer frame element (first part) **200** and a back plate **300** (second part) that mates with the outer frame element **200** to form the assembled frame. As described herein, the outer frame element **200** and the back plate **300** are attached to one another with a mechanical fit and more particularly, can snap-fittingly mate with one another.

The outer frame element **200** is a hollow piece that has a main body that defines a hollow center opening **205**. The outer frame element **200** can have any number of different shapes and sizes based on the intended shape and size of the framed article **10**. The main body of the outer frame element **200** has a plurality of (e.g., four) interconnected walls **202**, **204**, **206**, **208**. The illustrated main body has a square shape and therefore, each of the interconnected walls **202**, **204**, **206**, **208** can be in the form of a rail or the like. Each of the walls **202**, **204**, **206**, **208** has an outer surface **201** and an inner surface **203**. The illustrated outer surface **201** represents the portion of the frame system **100** that is readily visible and therefore, it can be smooth or it can have a decorative finish (and thus is not limited to being a smooth surface).

**Outer Frame Element 200**

The outer frame element **200** includes a plurality of recesses **220** that are formed along the inner surface **203**. As illustrated, there can be two recesses **220** formed along each of the walls **202**, **204**, **206**, **208**. For example, one recess **220** can be formed near one end of the respective wall, while the other recess **220** can be formed near the other end. The recesses **220** can be centrally located along the respective

walls **202**, **204**, **206**, **208** or the recesses **220** can be located closer to a rear edge **211** of the respective wall. The rear edge **211** is the edge that faces rearward when the frame system **100** is displayed in an intended manner. As shown in FIG. **11**, the recess **220** can have a forward beveled edge and a flat rear edge, with the forward beveled edge being further from the rear edge **211** compared to the flat rear edge of the recess **220** which can be thought of as defining a shoulder.

The outer frame element **200** also includes a plurality of protrusions (e.g. ribs) that are formed along the inner surface **203**. As shown in FIG. **5**, the plurality of protrusions comprises two or more sets of different protrusions formed along each of the walls **202**, **204**, **206**, **208**. For example, a set of first protrusions (ribs) **240** is provided; a set of second protrusions (ribs) **250** is provided; and a set of third protrusions (ribs) **260** is provided. Each first protrusion **240** is formed along the inner surface **203** and extends upwardly from an inner landing **210** that extends around the inner surface **203**.

The first protrusions **240** are elongated structures each having a first length. In the illustrated embodiment, there are two first protrusions **240** that are spaced along the length of each wall **202**, **204**, **206**, **208**. The first protrusions **240** extend towards but do not reach the rear edge **211**. As shown, all of the first protrusions **240** associated with each of the walls **202**, **204**, **206**, **208** can be located between the two recesses **220** formed along the respective wall **202**, **204**, **206**, **208**. The first protrusions **240** are integrally formed along the inner surface of the walls **202**, **204**, **206**, **208**.

The second protrusions **250** are elongated structures each having a second length. In the illustrated embodiment, there are six second protrusions **250** that spaced along the length of each wall **202**, **204**, **206**, **208**. The second protrusions **250** extend towards but do not reach the rear edge **211**. As shown, all of the second protrusions **240** associated with each of the walls **202**, **204**, **206**, **208** can be located between the two recesses **220** formed along the respective wall **202**, **204**, **206**, **208**. The second protrusions **250** are integrally formed along the inner surface **203** of the walls **202**, **204**, **206**, **208**.

The second length is less than the first length and therefore, the first protrusions **240** are longer and extend further up the inner face of the walls **202**, **204**, **206**, **208** compared to the second protrusions **250**.

The inner landing **210** has a channel or groove **212** formed therein. The channel **212** preferably extends completely around the inner landing **210**. The second protrusions **250** can have curved inner surfaces as shown in FIG. **6** and FIG. **6** also shows that the second protrusions **250** extend a greater distance into the channel **212** compared to the first protrusions **240**.

As shown in FIGS. **4-6**, the third protrusions **260** can be formed along the inner landing **210** and are spaced from the inner surface **203**. The second protrusions **250** can be in the form of bumps or elongated protrusions and extend in the direction toward the rear edge **211** much like the first and second protrusions **240**, **250**. Like the second protrusions **250**, the third protrusions **260** extend into the channel **212**. The third protrusion **260**, like the second protrusion **250**, can have a rounded (curved) surface. The second protrusions **250** and third protrusions **260** can generally have a pill shape or partial pill shape as shown.

The third protrusions **260** have third lengths that are less than both the first lengths of the first protrusions **240** and the second lengths of the second protrusions **250**. As best shown in FIG. **4**, all of the protrusions **240**, **250**, **260** extend outwardly from the inner landing **210**. The third protrusions

**260** are located on one side (inner side) of the channel **212** and the first protrusions **240** and the second protrusions **250** are located on the other side (outer side) of the channel **212**.

In the illustrated embodiment, there are two third protrusions **260** per each wall **202**, **204**, **206**, **208**. The two third protrusions **260** can be centrally located and be formed between a pair of second protrusions **250**.

As described herein, the three sets of protrusions **240**, **250**, **260** have different functionality.

Each of the walls **202**, **204**, **206**, **208** preferably has the same pattern of first, second and third protrusions **240**, **250**, **260**.

As described herein, the third protrusions **260** also serves as a surface against which the image substrate **20** is seated as shown in FIG. **3** in which the third protrusions **260** are not visible since they lie below the image substrate **20**. One feature of the inner surfaces of the second protrusions **250** is to locate the outer edge of the image substrate **20**. As shown in FIG. **3**, when the image substrate **20** is inserted into the outer frame element **200**, the outer edge of the image substrate **20** contacts and seats against the second protrusions **250**. In other words, the second protrusions **250** serves to align the image substrate **20** within the framing system **100**. The tops of the second protrusions **250** also serve as secondary stops that prevent the back plate **300** from being pushed into the outer frame element **200** (in a direction toward the image substrate **20**).

As also described herein, the first protrusions **240** act as bumper guards and they prevent the back plate **300** from shifting inside of the outer frame element **200**. In addition, the first protrusions **240** help keep the snap-fit attachment intact between the outer frame element **200** and the back plate **300**.

As mentioned, the back plate **300** is configured to be inserted into and mate with the outer frame element **200** and more particularly, according to one embodiment, a snap-fit connection is achieved between the outer frame element **200** and the back plate **300** as described herein.

The outer frame element **200** can be formed of any number of suitable materials including suitable plastics (e.g., injection molded plastics).

#### Back Plate **300**

The back plate **300** serves as the rear part of the frame assembly **100** that is located behind the image substrate **20** and the engagement of the back plate **300** to the outer frame element **200** serves to capture and hold the image substrate **20** between the back plate **300** and the outer frame element **200**.

As mentioned, the back plate **300** attaches to the outer frame element **200** and closes off the back of the frame system **100**. As also described herein, the image substrate **20** is disposed and held between the back plate **300** and the outer frame element **200** and more particularly, the user places the image substrate onto the inner landing **210** and then attaches the back plate **300** to the outer frame element **200**, thereby capturing the image substrate **20** therebetween.

As shown, the back plate **300** is inserted into the hollow opening of the outer frame element **200** with locking features of the back plate **300** engaging locking features of the outer frame element **200** to form a snap-fit. The back plate **300** has a complementary shape to the outer frame element **200** and therefore, in the illustrated embodiment, the back plate **300** is square shaped.

As best shown in FIGS. **7** and **8**, the back plate **300** has a first wall **302**, a second wall **304**, a third wall **306**, and a fourth wall **308** that are all interconnected to one another. Between the first wall **302**, the second wall **304**, the third



wall **306**, and the fourth wall **308**, an inner wall **310** is provided and extends between these walls. The inner wall **310** is thus designed to completely seal off the inner space between the walls **302**, **304**, **306**, **308**. The inner wall **310** has a front face that faces and contacts the image substrate **20** and an opposite rear face of the inner wall **310** faces away from the inner wall **310**.

Along the inner wall **310** there is a raised platform **320** that protrudes outwardly (rearwardly) from the inner wall **310**. The raised platform **320** has a center portion **322** and a plurality of leg portions **324** that extend from the center portion **322** to each of the walls **302**, **304**, **306**, **308**. Each of the leg portions **324** is defined by a curved (sloped) edge **326**. In the illustrated embodiment, there are four leg portions **324** and thus, four curved edges **326**. Between each curved edge **326** and one respective corner of the back plate **300**, there is a corner space **350** that has a wedge shape.

Within the center portion **322** of the raised platform **320** there can be a raised pad **325** that provides a surface on which mounting hardware can be secured. The mounting hardware is generally illustrated in FIG. 1 at element **50**. The mounting hardware **50** can take any number of different forms that are configured to attach the back plate **300** to a support surface, such as a wall. For example, the mounting hardware **50** can take the form of a square of double-sided tape or it can be in the form of a metal element (metal layer or plate). Preferably, the mounting hardware seats flush against the raised pad **325**.

As shown the raised pad **325** can have a square shape with the corners of the raised pad **325** being located close to the curved edges **326** of the raised platform **320**. The raised pad **325** thus serves to centrally locate the mounting hardware on the rear of the back plate **300**.

At the interface between each leg portion **324** and the side wall **302**, **304**, **306**, **308**, there is an opening (mounting opening) **400** that is configured to receive a fastener or a stand to assist in mounting the framed article to a wall or the like or to allow the framed article to stand upright on a flat surface, such as a table. The opening **400** has an inner edge **402** that is curved and an opposite outer edge **403** in the form of a concave notch that is formed in one of the walls **302**, **304**, **306**, **308**. A fastener, such as a nail, can be received within the concave notch as a way to hang the framed article on the fastener. The fastener can be inserted into a wall for hanging the framed article onto the wall. The use of opening **400** to receive a kickstand for allowing the framed article to stand upright on a table is described herein.

As previously mentioned, the back plate **300** snap-fittingly attaches to the outer frame element **200** and therefore includes locking features that mate with complementary locking features of the outer frame element **200**. For example, the back plate **300** includes a plurality of corner guides **360** best shown in FIG. 8. The corner guides **360** are in each corner and are L-shaped in that one wall of the corner guide **360** is located along one wall of the back plate **300** and the other wall of the corner guide **360** is located along the other wall of the back plate **300** that defines the corner. Each of the walls **302**, **304**, **306**, **308** of the back plate **300** terminates in a forward edge **315**. The walls of the corner guide **360** extend beyond the forward edge **315** in that the walls of the corner guide **360** have greater length (height) than the other sections of the walls **302**, **304**, **306**, **308**. The corner guide **360** is configured to be received within the channel **212** formed in the landing **210** as shown in FIG. 12. There are therefore four corner guides **360** in the illustrated back plate **300**. As also shown in FIG. 12, the image substrate **20** lies partially over the channel **212** with the

corner guide **360** being adjacent and in contact with the image substrate **20** since the corner guide **360** is disposed within the channel **212** and can be in contact with the floor of the channel **212**. FIG. 12 shows that the corner guide **360** is disposed between the outer edge of the image substrate **20** and the respective outer wall **202**, **204**, **206**, **208**.

An additional locking feature of the back plate **300** comprises a plurality of locking ribs **370** that are configured to be received into and engage the recesses **220** that comprise the complementary locking features of the outer frame element **200**. More particularly, the locking ribs **270** snap-fittingly mate with the recesses **220** to interlockingly couple the back plate **300** to the outer frame element **200**.

Each locking rib **370** comprises a flexible rib that is defined between two slots **373** formed in the wall **302**, **304**, **306**, **308** to allow the locking rib **370** to flex. At a forward end of the locking rib **370** an outwardly directed lip **375** is formed. The lip **375** is integrally formed with the rest of the locking rib **370**. As best shown in FIG. 11, the lip **375** has a complementary shape as the recess **220** in that it includes a beveled edge that seats against the beveled surface of the recess **220** and a flat edge that seats against the flat surface of the recess **220**. In FIG. 11, the locking rib **370** is snap-fittingly received into one respective recess **220**. The reception of the locking ribs **370** into corresponding recesses **220** results in a secure snap-fit being achieved between the outer frame element **200** and the back plate **300**.

There are two locking ribs **370** located along each side wall **302**, **304**, **306**, **308** and in particular, the two locking ribs **370** are located near or at the ends of the respective wall **302**, **304**, **306**, **308**. Thus, in each corner of the framed article, there is one corner guide **360** disposed between two locking ribs **370**. This leads to the main securement between the outer frame element **200** and the back plate **300** being located in the corners of the framed article.

As shown in the figures, including FIG. 11, the locking rib **370** has a local area of increased thickness and in particular, the local area can be in the form of a rail **371** or other protrusion that bulges slightly outward from the rest of the locking rib **370**. It will be appreciated that each of the two locking ribs **370** that define each corner has one rail **371**. As shown in FIG. 11, the rail **371** does not extend the entire height of the locking rib **370**.

As shown in FIG. 8, there is a center tab **380** that is located along the wall **302**, **304**, **306**, **308**. The center tab **380** also extends beyond the forward edge **315**. The center tab **380** is located between the two locking ribs **370** located along the same wall **302**, **304**, **306**, **308**. The center tab **380** is designed, in combination with the third protrusions **260**, to prevent an outward bowing of the framed article after assembly (i.e., outward flexing of the outer frame element **200**). The center tab **380** opposes the third protrusion **260**. More specifically, each center tab **380** is disposed outside of and in contact with one respective pair of the third protrusions **260**. The center tabs **380** are thus located between the third protrusions **260** and the walls **202**, **204**, **206**, **208** of the outer frame element **200** and since the center tab **380** is significantly more rigid than the hollow outer frame element **200**, the center tabs **380** which are located outside (along the outer face) of the outer frame element **200** prevents any deformation and outward bowing of the hollow outer frame element **200**.

Assembly of Frame System **100**

As mentioned, the frame system **100** is assembled to achieve a mechanical (snap-fit) between the outer frame element **200** and the back plate **300**.

First, the image substrate **20** is placed within the hollow outer frame element **200** and rests on the inner landing **210** that is formed along the inner periphery of the outer frame element **200**. The rear plate **300** is then inserted into the center opening **205** of the hollow outer frame element **200**. The corner guides **360** are received within the channel **212** formed in the landing **210** as shown in FIG. **12** and the rigid center tabs **380** are positioned outside of and adjacent the third protrusions **260**.

As shown in FIG. **17**, a plurality of raised platforms **329** are provided along the inner face of the back plate **300** on which the image substrate **20** rests. As shown, there are four platforms **329** on which the four corner regions of the image substrate **20** rests to ensure proper positioning and proper support of the image substrate **20** (the raised platforms **329** provide proper backing and push the image substrate **20** forward). The raised platforms **329** can be generally wedge shaped or triangular shaped as shown.

The snap-fit between the outer frame element **200** and the back plate **300** is achieved by inserting the locking ribs **370** into the (locking) recesses **220**. As shown in the figures, this results in the image substrate **20** being captured between the outer frame element **200** and the back plate **300**. The corner guides **360** serve also as a self-aligning feature for the image substrate **20**.

FIGS. **9-13** illustrate the details of how the outer frame element **200** snap-fits with the back plate **300** and the relative position of the image substrate **20**.

#### Kickstand

In yet another aspect of the present disclosure best shown in FIGS. **14-16**, a kickstand **500** can be provided. As mentioned, the back plate **300** includes a plurality of corner spaces **350** (FIG. **9**). One of the corner spaces **350** serves as a kickstand storage space. Within the corner space **350**, there is a post **355** that protrudes upwardly from the floor of the corner space **350** as shown in FIG. **8**. The post **355** has an undercut **357** formed therealong.

As shown in FIGS. **1** and **2**, the kickstand **500** has a curved body with a first end **502** and an opposite second end **504**. The first end **502** is a flat surface that is positioned along the support surface, such as a table. As shown in FIG. **16**, the body of the kickstand **500** also includes an opening **510** with a slot **511** that extends from the opening **510** to the second end **504**. The opening **510** receive the post **355** resulting in a snap-fit between the post **355** (due to the undercut **357** thereof) and the kickstand **500** for temporary storage of the kickstand **500**. When the user is ready to use the kickstand **500**, the kickstand **500** is removed from the post **355**.

The kickstand **500** also includes a slot **520** that defines a pair of locking snap-fit elements (e.g., locking tabs or catches) **530**. The snap-fit elements **530** are located at the end of two flexible prongs **540** that protrude outwardly from the second end **504**. These flexible prongs **540** are intended to be received within one opening **400** formed in the back plate **300** to achieve a snap fit between the kickstand **500** and the back plate **300**. As mentioned, the opening **400** has opposing edges to which the snap-fit element **530** can engage in a snap-fit manner. The flexible prong **540** allow for the snap-fit elements **530** to be initially received into the opening **400** and then flex outwardly into complementary locking edges formed in the opening **400**.

The snap-fit elements **530** of the two flexible prongs **540** engage the edges of the opening **400** to cause a snap-fit engagement between the kickstand **500** and the back plate **300**. As mentioned, when the kickstand **500** is inserted into

the opening **400**, the first end **502** faces downward and seats against the flat support surface (table surface).

Since there are four openings **400**, the kickstand **500** can be inserted into any one of the four openings **400**.

#### Disengagement Tool **600**

In one aspect of the present invention shown in FIG. **18**, a disengagement tool **600** can be used to easily disengage the outer frame element **200** from the back plate **300**. As shown, the disengagement tool **600** can be in the form of a curved card-like structure and more particularly, can comprise a 90 degree body defined by a two legs **602**, **604**. The shape and size of the tool **600** are selected in view of the dimensions of the frame assembly **100**.

The 90 degree disengagement tool **600** is inserted into a space **605** (FIG. **11**) that is formed between the locking rib **370** and one of the respective walls **202**, **204**, **206**, **208** when the lip **375** is engaged with the recess **220** which results in the outer frame element **200** and the back plate **300** being coupled and engaged with one another. When the tool **600** is pressed down into the space **605** it encounters the rails **371** of the two locking ribs **370** that are formed at 90 degree angles and further movement of the tool **600** and increased contact with the rails **371** causes inward flexing of the locking ribs **370** and disengagement of the lips **375** from the respective recesses **220**, thereby freeing the respective corner of the framing system **100**.

The disengagement tool **600** has two legs that are formed at 90 degrees since for the corner of the framing system **100** will not easily disengage unless both side walls of the corner disengage at the same time. If the disengagement tool **600** only had one leg and was inserted into only one space **605**, the corner will not easily disengage. As a result, the disengagement tool **600** has two legs and has a card-like construction.

As mentioned, to use the disengagement tool **600**, the user simply inserts the bottom edge of the tool **600** into the space **605** and then pushes down until the bottom edge of the tool **600** contacts and rides over the two rails **371** causing inward flexing of the locking ribs **370** to disengage the locking ribs **370** from the recesses **220**.

Once one corner of the framing system **100** becomes disengaged, the entire outer frame element **200** can be fairly easily removed. Alternatively, each corner of the framing system **100** can be disengaged using the disengagement tool **600**.

It is to be understood that like numerals in the drawings represent like elements through the several figures, and that not all components and/or steps described and illustrated with reference to the figures are required for all embodiments or arrangements.

The terminology used herein is for the purpose of describing particular embodiments only and is not intended to be limiting of the invention. As used herein, the singular forms "a", "an" and "the" are intended to include the plural forms as well, unless the context clearly indicates otherwise. It will be further understood that the terms "comprises" and/or "comprising", when used in this specification, specify the presence of stated features, integers, steps, operations, elements, and/or components, but do not preclude the presence or addition of one or more other features, integers, steps, operations, elements, components, and/or groups thereof.

Also, the phraseology and terminology used herein is for the purpose of description and should not be regarded as limiting. The use of "including," "comprising," or "having," "containing," "involving," and variations thereof herein, is meant to encompass the items listed thereafter and equivalents thereof as well as additional items.

The subject matter described above is provided by way of illustration only and should not be construed as limiting. Various modifications and changes can be made to the subject matter described herein without following the example embodiments and applications illustrated and described, and without departing from the true spirit and scope of the present invention, which is set forth in the following claims.

What is claimed is:

1. A frame system for holding an image substrate comprising:

a hollow outer frame element that includes a plurality of recesses formed along inner faces of walls of the outer frame element, the outer frame element further including a plurality of ribs formed along the inner face and an inner landing that protrudes inwardly into a center opening of the outer frame element; and

a back plate configured for insertion into the center opening, the back plate including a plurality of locking ribs for reception within the plurality of recesses to generate a snap-fit attachment of the back plate to the hollow outer frame element;

wherein the back plate includes a plurality of corner guides that are received within a channel formed in the inner landing and assist in self-aligning the image substrate.

2. The frame system of claim 1, wherein the plurality of ribs includes a set of first ribs formed along the inner face, a set of second ribs formed along the inner face; and a set of third ribs that extend outwardly from the inner landing and are spaced from the inner face.

3. The frame system of claim 2, wherein the set of third ribs are formed on an inner side of the channel of the inner landing and the set of second ribs and the set of first ribs are located on an outer side of the channel.

4. The frame system of claim 3, wherein the back plate includes a plurality of center tabs, wherein each wall of the back plate includes two locking ribs and one center tab located between the two locking ribs, the center tab being disposed adjacent and in contact with one pair of third ribs, each center tab between disposed between one pair of third ribs and one respective wall of the outer frame element.

5. The frame system of claim 4, wherein the set of second ribs have curved surfaces that face inwardly and are intended to contact an image substrate that seats against the inner landing and is captured between the outer frame element and the back plate.

6. The frame system of claim 1, wherein each corner of the frame system is defined by one pair of locking ribs of the plurality of locking ribs that are formed at a 90 degree angle relative to one another and each locking rib of the pair of locking ribs having a localized protrusion that extends outwardly toward to outer frame element and when the plurality of locking ribs are received with the plurality of recesses, a space is formed between the plurality of plurality of locking ribs and the outer frame element and is open along a rear edge of the frame system.

7. The frame system of claim 6, further comprising a disengagement tool comprising a substrate that is bent at a 90 degree angle, the disengagement tool being configured for reception within the space and for contacting the localized protrusions to cause inward flexing of the plurality of locking ribs and disengagement of the plurality of locking ribs from the plurality of recesses to permit separation of the outer frame element from the back plate.

8. The frame system of claim 6, wherein the disengagement tool comprises a plastic card bent at the 90 degree angle.

9. The frame system of claim 1, wherein the plurality of ribs includes a first set of ribs that are formed along the inner face for positioning against an outer peripheral edge of the image substrate.

10. The frame system of claim 1, wherein the corners guides have walls formed at a right angle to allow each corner guide to engage the channel of the inner landing in each corner.

11. The frame system of claim 10, wherein each corner guide is located between two locking ribs formed along perpendicular walls of the back plate.

12. A frame system for holding an image substrate comprising:

a hollow outer frame element that includes a plurality of recesses formed along inner faces of walls of the outer frame element, the outer frame element further including a plurality of ribs formed along the inner face and an inner landing that protrudes inwardly into a center opening of the outer frame element; and

a back plate configured for insertion into the center opening, the back plate including a plurality of locking ribs for reception within the plurality of recesses to generate a snap-fit attachment of the back plate to the hollow outer frame element;

wherein the back plate includes a raised platform that defines corner areas that are recessed relative to the raised platform, wherein one corner area includes a locking post for detachably coupling to a kickstand that is configured for reception into an engagement with one mounting opening that is formed in the back plate.

13. The frame system of claim 12, wherein the locking post includes a circumferential undercut and the locking post is received within an opening formed in the kickstand, the opening being open to an in communication with one edge of the kickstand via a slit that allows flexing of the kickstand.

14. A frame system for holding an image substrate comprising:

a hollow outer frame element that includes a plurality of recesses formed along inner faces of walls of the outer frame element, the outer frame element further including a plurality of ribs formed along the inner face and an inner landing that protrudes inwardly into a center opening of the outer frame element; and

a back plate configured for insertion into the center opening, the back plate including a plurality of locking ribs for reception within the plurality of recesses to generate a snap-fit attachment of the back plate to the hollow outer frame element;

wherein the back plate is defined by four walls with each of the four walls including a center tab and the outer frame element includes four walls with each of the four walls including one pair of center protrusions that are opposed by the center tab on the adjacent wall of the back plate, the combined center tab and pair of center protrusions configured to prevent outward flexing of the outer frame element relative to the back plate.

15. A frame system for holding an image substrate comprising:

a hollow outer frame element that includes a plurality of recesses formed along inner faces of walls of the outer frame element, the outer frame element further including a plurality of ribs formed along the inner face and an inner landing that protrudes inwardly into a center opening of the outer frame element; and

11

a back plate configured for insertion into the center opening, the back plate including a plurality of locking ribs for reception within the plurality of recesses to generate a snap-fit attachment of the back plate to the hollow outer frame element;

wherein the inner landing has a channel formed therein and an inner edge of the inner landing has a plurality of protrusions formed integrally with the inner landing and extending outwardly from the inner edge, the plurality of protrusions being configured for positioning the image substrate thereon.

16. A framed article comprising an image substrate having a front face and an opposite rear face; and

a frame system for holding the image substrate, the frame system comprising:

a hollow outer frame element that includes a plurality of recesses formed along inner faces of walls of the outer frame element, the outer frame element further including a plurality of ribs formed along the inner face and an inner landing that protrudes inwardly into a center opening of the outer frame element, wherein the outer frame element includes an inwardly directed lip that has a first contact surface; and

a back plate configured for insertion into the center opening, the back plate including a plurality of

12

locking ribs for reception within the plurality of recesses to generate a snap-fit attachment of the back plate to the hollow outer frame element, wherein the back plate has a plurality of corner platforms that define second contact surfaces;

wherein the front face of the image substrate seats against the first contact surface and the rear face of the image substrate seats against the second contact surfaces.

17. The framed article of claim 16, wherein each corner of the frame system is defined by one pair of locking ribs of the plurality of locking ribs that are formed at a 90 degree angle relative to one another and each locking rib of the pair of locking ribs having a localized protrusion that extends outwardly toward to outer frame element and when the plurality of locking ribs are received with the plurality of recesses, a space is formed between the plurality of plurality of locking ribs and the outer frame element and is open along a rear edge of the frame system.

18. The framed article of claim 17, further comprising a disengagement tool comprising a substrate that is bent at a 90 degree angle, the disengagement tool being configured for reception within the space and for contacting the localized protrusions to cause inward flexing of the plurality of locking ribs and disengagement of the plurality of locking ribs from the plurality of recesses to permit separation of the outer frame element from the back plate.

\* \* \* \* \*